

BUILT-IN GAS HOB
BATTERY IGNITION

Model:

- HB FG 3060 TN VSB [141252-11]
- HB FG 3070 TN VSB [141253-11]
- HB FG 4060 TN VSB [141250-11]
- HB FG 4090 TN VSB [141251-11]
- HB FG 5070 TN VSB
- HB FG 5090 TN VSB



THE BEAUTY OF SIMPLICITY

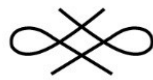

USER MANUAL



HB FG 3060 TN VSB



HB FG 4060 TN VSB



HB FG 3070 TN VSB



HB FG 4090 TN VSB



HB FG 5090 TN VSB



HB FG 5070 TN VSB

Congratulations on choosing our product, which you will find is dependable and easy to use. We recommend that you read this manual for best performance and to extend the life of your appliance. Thank you.

Close-up View

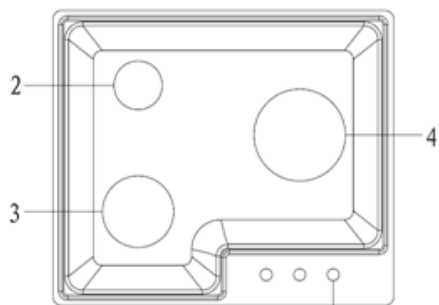

HB FG 3060 TN VSB

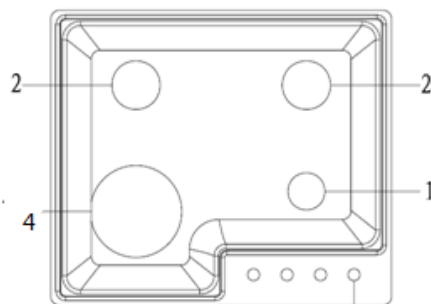

HB FG 4060 TN VSB

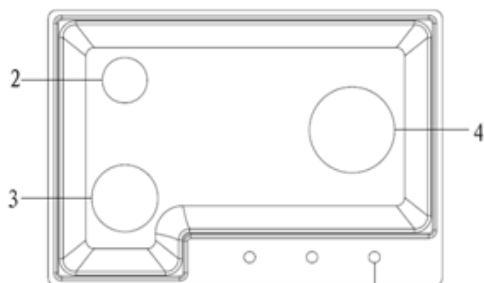

HB FG 3070 TN VSB

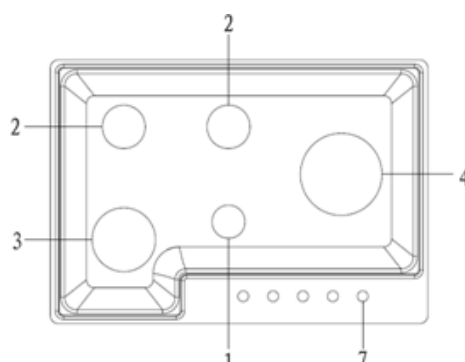

HB FG 5070 TN VSB

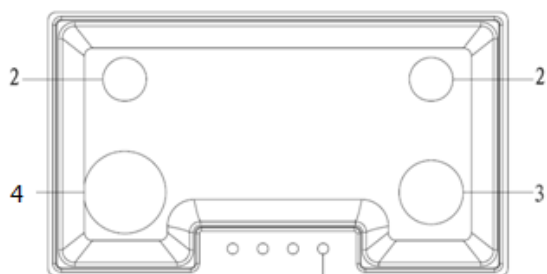

HB FG 4090 TN VSB

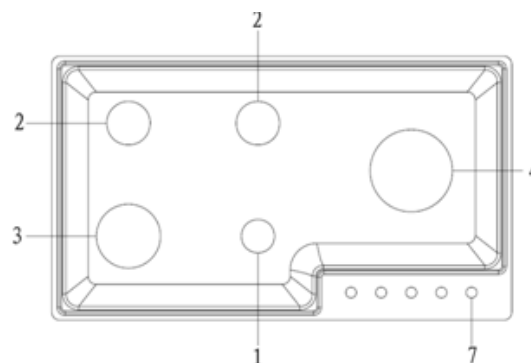

HB FG 5090 TN VSB

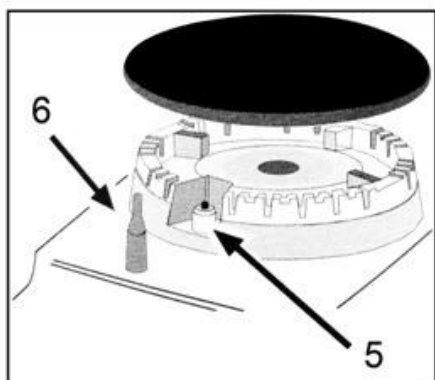

1. Auxiliary Gas Burners
2. Semi-rapid burner
3. Rapid burner
4. Triple ring burner
5. Igniter for Gas Burners (only on certain models)
6. Safety Device (only on certain models) - Activates if the flame accidentally goes out (spills, drafts, etc.), interrupting the delivery of gas to the burner.
7. Control Knobs for Gas Burners and Electric Hot Plates

How To Use Your Appliance

The position of the corresponding gas burner is indicated on each control knob.

GAS BURNERS

The burners differ in size and power. Choose the most appropriate one for the diameter of the cookware being used.

The burner can be regulated with the corresponding control knob by using one of the following settings:

- OFF
- ★ High
- Low

IGNITING THE BURNERS

All models come with auto ignition and the safety device. Proceed as follows to ignite the burner:

- 1) Turn the chosen knob in anti-clockwise direction to the "High" setting.
- 2) Push in and hold the knob for 3 to 5 seconds to light the gas and to permit the thermocouple to heat up.
- 3) Release the knob after 3 to 5 seconds and adjust the flame as desired. Repeat points 1 and 2 if the flame cannot be lighted.

Caution: If the burner accidentally goes out, the safety valve will automatically cut out the gas flow. To re-light the burner, turn the control knob back to "OFF" setting and try to re-light again after waiting for at least 1 minute.

Turn off a burner, turn the knob in the clockwise direction until it stops (it should be on the "●" OFF setting).

BATTERY IGNITION

If the auto ignition does not work, make sure that the battery, installed at the back of the cooker, is not flat and has been installed correctly.

CHOSE OF THE BURNERS

For greater efficiency and lesser gas consumption, use the pots and pans with the right diameters of the burners. Avoid having flames extending out from underneath the pans (refer to the table). A smaller diameter pot or pan placed on a larger burner does not necessarily mean that the boiling conditions are reached quicker.

Table of recommended pans	
Burner	Ø Pan diameter in cm
Auxiliary	from dia. 8 to dia. 14
Semi rapid	from dia. 14 to dia. 20
Rapid	from dia. 20 to dia. 28
Triple ring	Above dia. 26

AUTOMATIC SAFETY VALVES

This safety device automatically closes the gas valve if the inconvenience caused by failure to comply with this rule.

Cleaning and Maintenance

Cleaning and maintenance should be carried out after the appliance has turned cold especially when cleaning the enameled parts. Avoid leaving alkaline or acid substances (lemon juice, vinegar etc.) on the surfaces. Avoid using acid or chlorine-based cleaning products.

To extend the life of the cooktop, it is absolutely indispensable that the appliance be cleaned carefully and thoroughly on a frequent basis, keeping in mind the following:

- **BURNERS AND GRIDS** These parts can be removed and cleaned with soapy water or with non-abrasive products. After cleaning the burners and their flame distributors must be well dry (Failure to do so, it may cause the burner cap to be rusty) and correctly replaced. It is very important to check that the burner flame distributor **F** and the cap **C** has been correctly positioned (fig.1), failure to do so can cause serious problems. Check that the electrode "S" (fig.1) is always clean to ensure trouble-free sparking. Check that the probe "T" (fig.1) is always clean to ensure correct operation of the safety valves (for models with safety device).
- **STAINLESS STEEL** can be stained if it remains in contact with highly calcareous water or aggressive detergents (containing phosphorous) for an extended period of time, it is recommended that these parts be rinsed thoroughly with water and then dry well, It is also advisable to clean up any spills.
Note: regular use could cause discoloring around the burners due to high flame temperature.

Both the probe and ignition plug must be very carefully cleaned

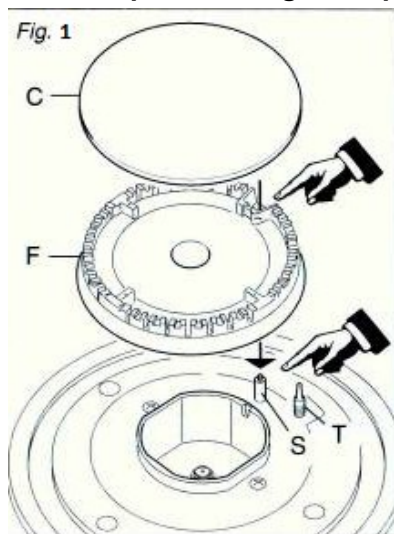

●GAS TAPS

Periodic lubrication of the gas taps must be carried out by specialist personnel only. In the event of operating faults in the gas taps, call the Service Department.

GENERAL ADVICE

- ✓ When the appliance is not being used; it is advisable to keep the gas tap closed.
- ✓ If the gas tap becomes stiff, it is necessary to dismount it accurately, clean it with gasoline and spread a bit of special grease resistant to high temperatures on it. This operation must be executed by a qualified technician.

TRIPLE RING BURNER

The triple ring burner must be correctly positioned (seen fig.2); the burner rib must be entered in their lodgment as shown by the arrow. The burner correctly positioned must not rotate (fig.3).

Then position the cap **A** and the ring **B** (fig.3).

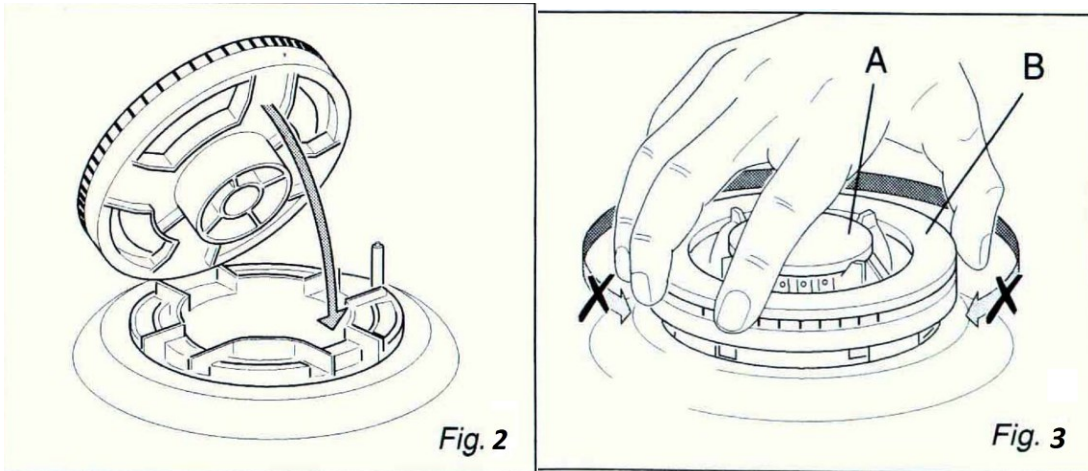

CLEANING THE TRIPLE RING BURNER

Pay special attention to this burner: the four holes around the outside of the crown must always be kept clean. When cleaning, remove the flame divider (fig.4) and use a cotton bud, toothbrush or some other item to clean out any incrustations or dirt from the four holes marked "H" (fig.5). This procedure is necessary to ensure the burner functions correctly.

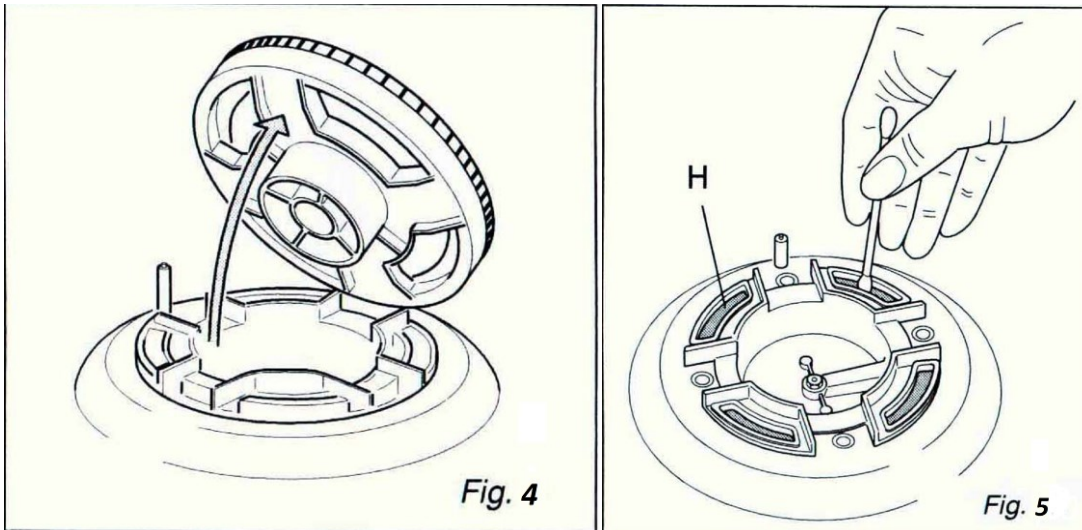

Greasing the Gas Valves

Over time, the gas valves may become difficult to turn. If this is the case, the inside of the valve must be cleaned and greased.

N.B.: This procedure must be performed by a technician authorized by the manufacturer.

Advice for the Installer

IMPORTANT:

- The appliance should be installed, regulated and adapted to function with other types of gas by a QUALIFIED INSTALLATION TECHNICIAN.
- Failure to comply with this condition will render the guarantee invalid.
- The appliance must be installed in compliance with regulations in force in your country and in observation of the manufacturer's instructions.
- Always unplug the appliance before carrying out any maintenance operations or repairs.
- Some appliances are supplied with a protective film on steel and aluminum parts. This film must be removed before using the cooker.
- The walls of the units must not be higher than work top and must be capable of resisting temperatures of 75°C above temperature.
- Do not install the appliance near inflammable materials (eg.curtains).

TECHNICAL INFORMATION

The cooktops are designed to be embedded into kitchen fixtures measuring 600 mm in depth.

In order to install the cook top into the kitchen fixture, a hole with the dimensions shown at the cutting size board has to be made, keeping in consideration the following:

- √ within the fixture, between the bottom side of the cooker top and the upper surface of any other appliance or internal shelf there must be a clearance of at least 30 mm;
- √ the cooker top must be kept no less than 100 mm away from any side wall;
- √ the hob must be installed at least 50mm away from the rear wall.
- √ there must be a distance of at least 650 mm between the hob and any wall cupboard or extractor hood positioned immediately above(fig.6).
- √ It is essential to install a heat baffle between the bottom of the hob and the underlying unit.

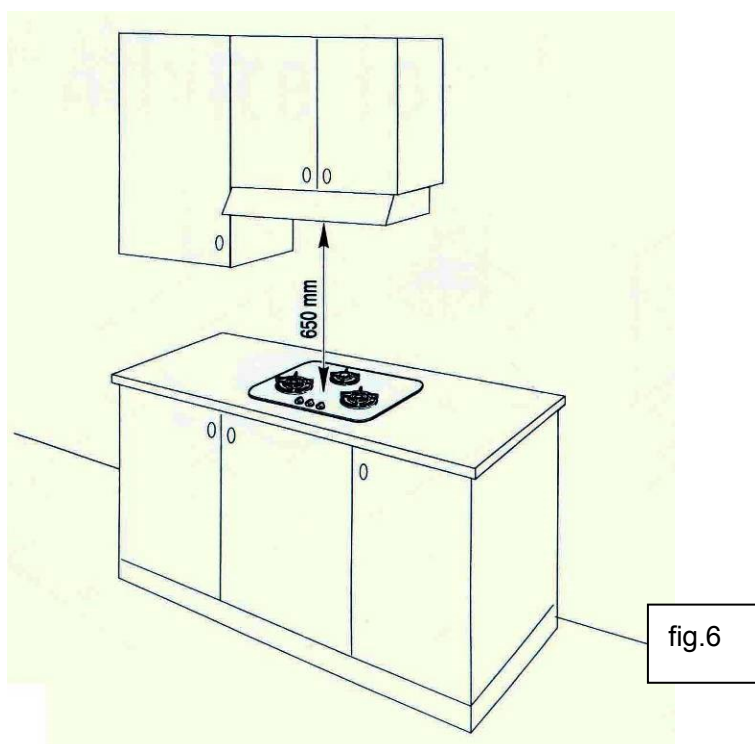

INSTALLATION IN KITCHEN CABINET WITH DOOR (fig.7)

The fixture has to be made according to specific requirements in order to prevent the gas burners from going out, even when the flame is turned down to minimum, due to pressure changes while opening or closing the cupboard doors. It is recommended that a 30 mm clearance be left between the cooker top and the fixture surface (fig.7).

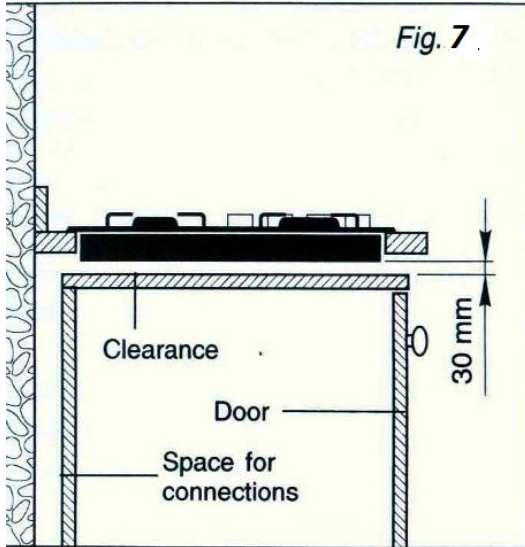

CHOOSING SUITABLE SURROUNDINGS

The room where the gas appliance is to be installed must have a natural flow of air so that the gas can burn. The flow of air must come directly from one or more openings made in the out-side walls with a free area of at least 100cm^2 . If the appliance does not have a no-flame safety device this opening must have an area of at least 200cm^2 . The openings should be near the floor and preferably on the side opposite the exhaust for combustion products and must be so made that they cannot be blocked from either the outside or the inside. When these openings cannot be made the necessary air can come from an adjacent room which is ventilated as required, as long as it is not a bedroom or a dangerous area. In this case the kitchen door must allow the passage of the air.

DISCHARGING PRODUCTS OF COMBUSTION

Extractor hoods connected directly to the outside must be provided, to allow the products of combustion of the gas appliance to be discharged (fig.8). If this is not possible, an electric fan may be used, attached to the external wall or the window; the fan should have a capacity to circulate air at an hourly rate of 3-5 times the total volume of the kitchen (fig.9). The fan can only be installed if the room has suitable vents to allow air to enter, as described under the heading "Installation room"

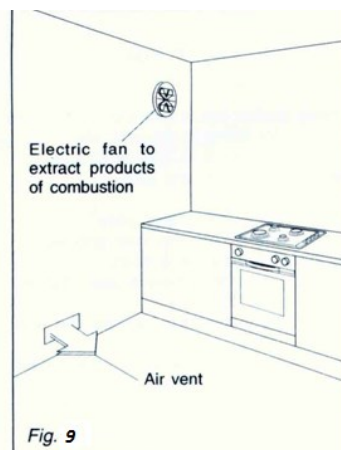
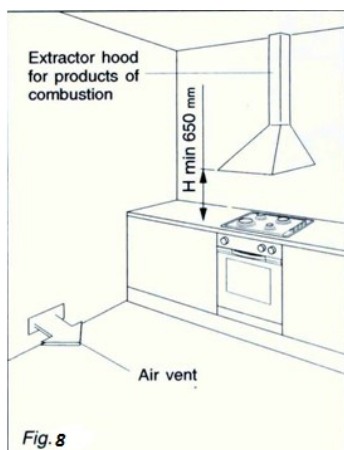

SETTLING UP THE HOB FOR INSTALLATION

Every cooker top is provided with a set of tabs for fitting to the fixture panel with thickness from 3 to 4 cm and a seal with adhesive on one side.

- Remove burners and grids.
- Turn the cooker top over.
- Place the battery in the battery compartment.
- Apply the self-adhesive seal “G” as illustrated in fig.10.
- Slot the cooker top into the unit and position.
- Position the cooker top in the recess and secure by means of the brackets as shown in fig.11 (for 3 or 4 cm thick work top).

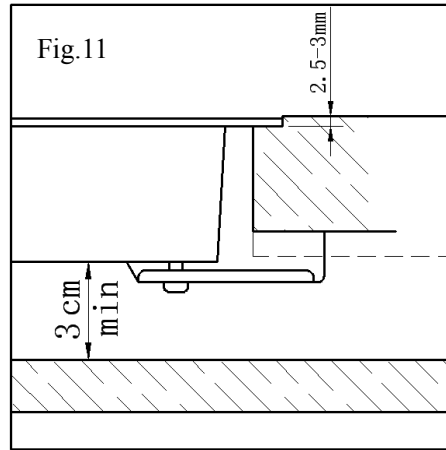
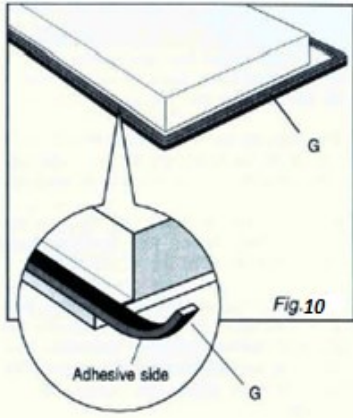

CUT-OUT DIMENSION

Different models cut-out dimension are different, make sure use the correct dimension to installation.

Model	Cut Out Dimension (Bottom cover) WC X DC	Cut Out Dimension (Panel) WP X DP	Distance Between Two Cut Out Dimension
HB FG 3060 TN VSB	563 X 483 mm	580x500 mm	Height: 2.5-3.0mm; Width:9mm
HB FG 4060 TN VSB			
HB FG 3070 TN VSB	703 X 483 mm	720x500 mm	Height: 2.5-3.0mm; Width:9mm
HB FG 5070 TN VSB			
HB FG 4090 TN VSB	843 X 483 mm	870x500 mm	Height: 2.5-3.0mm; Width:9mm
HB FG 5090 TN VSB			

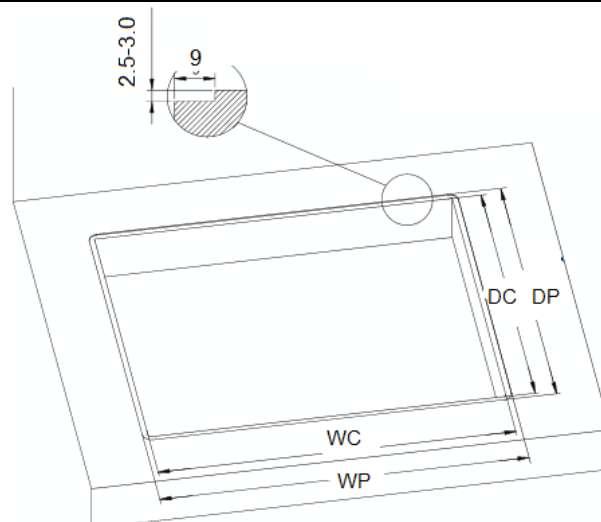

GAS SECTION

TYPES OF GAS

The gas may be grouped, in view of their features in three families:

- L.P.G.(in cylinders) G30
- NATURAL GAS(methane) G20
- City Gas G110

Adapting the Cooktop for DifferentTypes of Gas [Table1]

Burners and Nozzle Specifications

Burner	G20		G30				G110	
	Thermal power (kW)	Nozzle 1/100 (mm)	Thermal power kW	Nozzle 1/100 (mm)	Nozzle 1/100 (mm)	Nozzle 1/100 (mm)	Thermal power kW	Nozzle 1/100 (mm)
Auxiliary (Small) (A)	0.90	69	0.90	50	44	43	0.9	1.5
Semi rapid (Medium)	1.88	97	1.88	68	64	60	1.88	1.7
Rapid (R)	2.40	110	2.40	78	72	68	2.4	2.4
Triple Ring (TR)	3.40	123	3.40	91	86	83	3.4	2.6
Triple-ring (BSI burner)	2.65	124	2.65	84	78	70	NA	NA
Triple Ring (Tinon burner)	3.00	131	3.00	86	82	75	NA	NA
Supply pressures	20mbar			30 mbar	36 mbar	50 mbar	1mbar	

Table1

At 15°C and 1013 mbar-dry gas

P.C.I.G20	37.78 MJ/m ³	P.C.I.G25.1	32.51 MJ/m ³
P.C.I.G25	32.49 MJ/m ³	P.C.I.G27	30.98 MJ/m ³
P.C.I.G2.350	27.20MJ/ m ³	P.C.I.G30	49.47MJ/Kg

IMPORTANT: By default, the hob comes with nozzles suitable for PUB

The appliance should be installed, regulated and adapted to function with other types of gas by a **QUALIFIED INSTALLATION TECHNICIAN**.

INSTALLATION

The appliance is predisposed and adjusted to operate with the gas indicated in the specifications plate applied onto the appliance.

If the appliance must be operated with a gas different than that indicated on the plate, it is necessary to execute the following operations:

- replacement of the injectors
- regulating of the minimum

GAS CONNECTION FOR GAS HOB

The Cooker should be connected to the gas-supply by licensed installer. During installation of this product it is essential to fit an approved gas tap to isolate the supply from the appliance for the convenience of any subsequent removal or servicing. Connection of the appliance to the gas mains or liquid gas must be carried out according to the prescribed regulation in force, and only after it is ascertained that it is adaptable to the type of gas to be used. If not, follow the instructions indicated in the paragraph headed "Adaptation to different gas types". In the case of connection to liquid gas, by tank, use pressure regulators that conform to the regulation in force.

IMPORTANT: For safety, for the correct regulation of gas use and long life of the appliance, ensure that the gas pressure conforms to the indications given in table 1 "Nozzle and burner characteristics".

ORIENTATION OF THE ELBOW

The appliance is supplied with a gas connection. The connection to the gas supply must be effected only from the default position or in vertical position by turning the elbow downwards. To turn the elbow, follow these operations:

- √ Loosen the nut
- √ Turn the elbow
- √ Lock the nut
- √ Make sure there is no leakage by a soapy solution.

INSTALLATION INSTRUCTIONS FOR FIXING GAS COOKER ELBOW JOINT

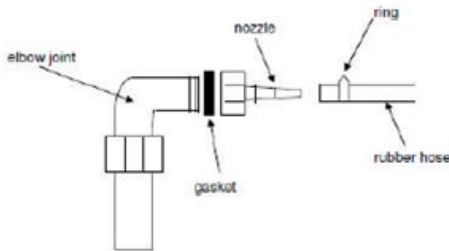

The gasket depicted above is to prevent gas leakage. After installation, turn on the gas supply and use soap solution (never use naked flame) to check for gas leakage.

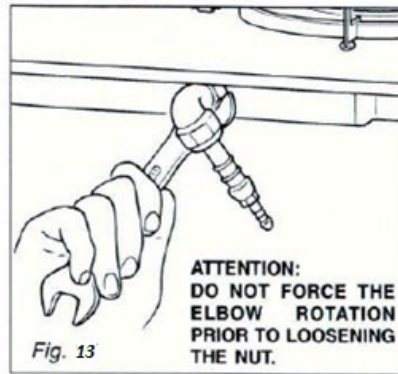

IMPORTANCES:

- √ Never attempts to turn the elbow without having first slackened off the relative lock nipple.
- √ The seals are the elements that guarantees the seal in the gas connection. It is recommended that they be replaced whenever they shows even the slightest deformation or imperfection.
- √ After connecting to the mains, check that the couplings are correctly sealed, using soap solution, but never use naked flame.
- √ The connection with rigid metal pipes should not cause stresses to the hob ramp.
- √ If the rubber tube is used for the gas connection:
 - Make sure the tube is snugly fit at both ends and use a standard tube clamp (not supplied) to fasten it.
 - The rubber tube must be as short as possible, without contractions or kinks.
 - The rubber tube must never be at any point in its length in contact with the "hot" parts.
 - From time to time check to make sure that the rubber is in perfect condition.

OPERATIONS TO BE PERFORMED WHEN SUBSTITUTING THE INJECTORS

If the injectors are not supplied they can be obtained from the "Service Centre".

Fig. 14

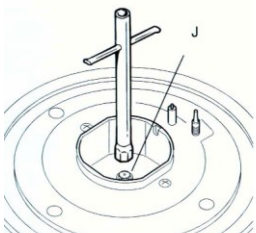

- √ Remove the gratings and the burner covers;
- √ Using a wrench, substitute the nozzle injectors; "J" (Fig.14) with those most suitable for the kind of gas for which it is to be used.
- √ The burners are conceived in such a way so as not to require the regulation of the primary air.

REGULATING THE BURNER MINIMUM SETTING

When switching from one type of gas to another, the minimum flow rate must also be correct. The flame should not go out even when passing suddenly from maximum to minimum flame. To regulate the flame follow the instructions below:

- ✓ Light the burner
- ✓ Set the cock valve to minimum

On gas valves provided with adjustment screw in the centre of the shaft (fig.15)

✓ Using a screwdriver with max. diameter 3 mm, turn the screw inside the tap until the correct setting is obtained.

On gas valves provided with adjustment screw on the valve body (fig.16):

✓ Turn the screw "A" to the correct setting with a screwdriver. Normally for G30 gas, fully tighten the adjustment screw.

LUBRICATION OF THE GAS TAPS

If the gas tap becomes stiff, it is necessary to dismount it accurately clean it with gasoline and spread a bit of special grease which resistant to high temperatures on it.

The operations must be executed by a qualified technician.

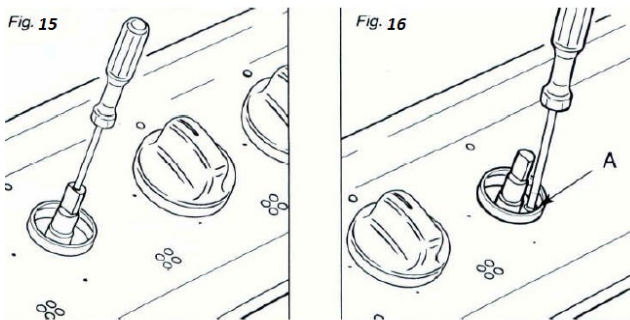

INSTALLING THE BATTERY

Insert a DC1.5V battery into the battery compartment (see below figures) in the cover. This battery is the power supply for the electronic ignition of gas burners.

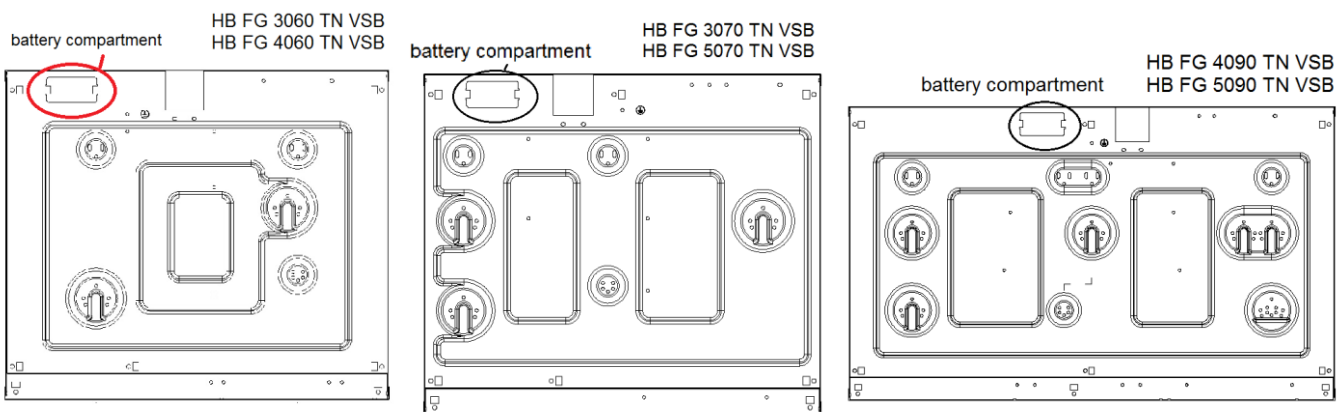

Notes for battery installation or replacement (see below fig.17, fig.18)

- Only use a DC1.5Volt battery.
- Check for correct polarity (label to the side of the battery compartment).the electronic ignition is used

Important notes:

- Remove the battery if the cooker is not going to be used for a long time.
- If the battery leaks, replace it immediately.

- Avoid touching the leaked liquid and make sure it does not come into contact with clothes or other items.
- Clean the battery compartment carefully before installing the new one.
- Note: The battery is a potential source of danger for children. Keep them away.
- Dispose of flat batteries properly.

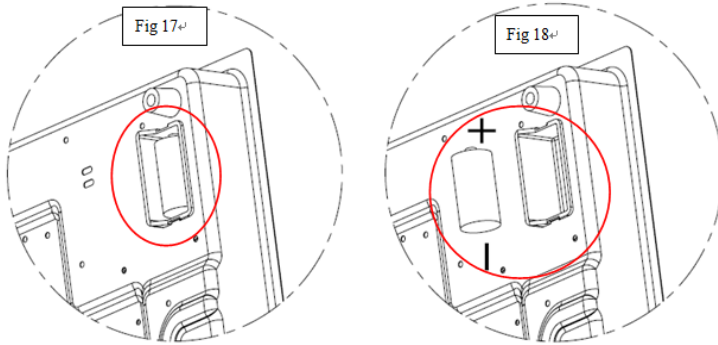

REPLACEMENT OF BURNER NOZZEL

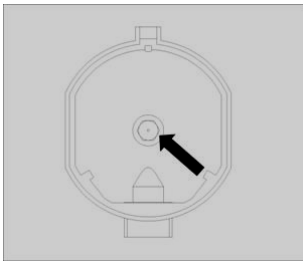

Loosen the nozzle with a dedicated wrench (7).Fit the new nozzle, suitable for the required gas type (see table above for reference).

After you have converted the cooktop to another gas type, make sure you have placed a label containing that information on the appliance.

Adjustment of the reduced valve flow

Table2

Burners	Flame	Converting the cooktop from LPG to natural gas	Converting the Cooktop from natural Gas to LPG
Regular burners	Full flame	Replace the burner Nozzle according To the guidelines in table 1	Replace the burner Nozzle according to the guidelines in table 1
	Saving flame	Loosen the adjustment Spindle (see fig.19 below) And adjust the flame	Loosen the adjustment Spindle (see fig.19 below) And adjust the flame

Valve adjustment

Valve adjustment should be done with the control knob set at Burner ON saving flame position. Remove the knob, and adjust the flame with a tiny screwdriver (see fig.19 below).

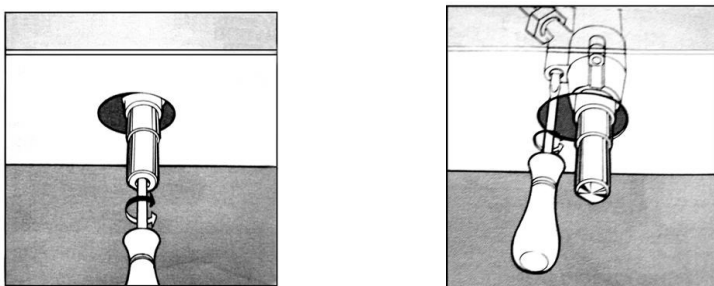

Fig.19

Checking the adjusted flame: heat the burner at full open position for 10 minutes. Then turn the knob into the saving setting. The flame should not extinguish nor move to the nozzle. If it goes off or moves over to the nozzle, readjust the valves.

Note.

It is up to the user to request converting the appliance to another gas type if so required by the local conditions at a licensed gas fitter/ service.

Flame selection

At the burners adjusted correctly, the flames should be light blue, and the inner cone should be clearly visible. The size of flame depends on the position of the related burner control knob.

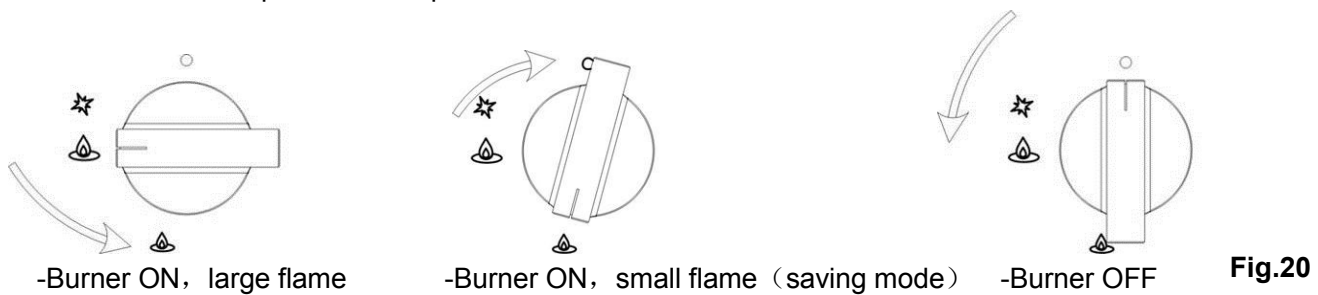

Fig.20

See also fig.20 for various operating options (flame size selection); the burner should be set at a large flame during the initial phase of cooking to bring the food to boiling, and then the knob should be turned to the saving flame position to maintain the cooking. It is also possible to adjust the flame size freely.

It is prohibited to adjust the flame in the range between the Burner OFF and Burner ON large flame positions.

Significant quantities of energy can be saved if the appliance is used correctly, parameters set correctly, and appropriate cookware is used. The savings can be as follows:

- Up to 60 per cent savings when proper pots are used,
- Up to 60 per cent savings when the unit is operated correctly and the suitable flame size is chosen.

It is a prerequisite for efficient and energy-saving operation of the cooktop that the burners are kept clean at all times (in particular the flame slots and nozzles).

For after sales service [Singapore], please contact

Casa (S) Pte Ltd
15, Kian Teck Crescent, Singapore 628884
Telephone: 6268 0077
Email: service@casa.com.sg